



**POWER TONGUE JACK  
OWNER'S MANUAL**

**L I P P E R T  
C O M P O N E N T S<sup>®</sup>**

# TABLE OF CONTENTS

<b>Product Information</b> .....	<b>2</b>
<b>Safety</b> .....	<b>3</b>
<b>Operation</b> .....	<b>4</b>
Unhitching From Tow Vehicle.....	<b>4</b>
Hitching to Tow Vehicle.....	<b>4</b>
Manual Operation.....	<b>5</b>
<b>Troubleshooting</b> .....	<b>6</b>
Fuse.....	<b>6</b>
Clutch.....	<b>6</b>
<b>Additional Information Sources</b> .....	<b>6</b>
<b>Power Tongue Jack Assembly</b> .....	<b>7</b>
<b>Power Tongue Jack Components</b> .....	<b>8</b>
<b>Power Tongue Jack Components</b> .....	<b>9</b>

## Product Information

This manual provides general service and maintenance procedures. Many variables can change the circumstances of the service procedure, ie., the degree of difficulty involved in the service operation and the ability level of the individual performing the operation. This manual cannot begin to plot out procedures for every possibility, but will provide the general instructions for effectively servicing the vehicle. In the event the skill level required is too high or the procedure too difficult, a certified technician should be consulted before performing the necessary service. Our 3,500 lbs. capacity Power Tongue Jacks make lifting and lowering a trailer so easy. With just the flip of the switch, the power tongue jack lifts a trailer with ease. Helical cut gears reduce noise and improve operating efficiencies, and four LED lights makes setting up camp simple, day or night. The owner's manual for the trailer may have more procedures for service and maintenance.

**NOTE:** The power tongue jack is designed for vertical movement of the trailer only.

## Safety

### **WARNING**

The “WARNING” symbol above is a sign that a service or maintenance procedure has a safety risk involved and may cause death or serious injury if not performed safely and within the parameters set forth in this manual.

### **WARNING**

Always wear eye protection when performing service or maintenance to the vehicle. Other safety equipment to consider would be hearing protection, gloves and possibly a full face shield, depending on the nature of the service.

### **WARNING**

Failure to correctly service the vehicle may result in death, serious injury or property damage.

### **WARNING**

- Never allow anyone unfamiliar with this product to install, operate or service this product.
- Never lift or level the trailer without a properly installed footpad.
- Never crank the jack or couple the trailer without preventing the trailer from rolling.
- Never exert excessive side forces to the power tongue jack.
- Never allow anyone, including the operator, to put any body parts under the power tongue jack or the supported load during jack operation.
- Never drop the trailer off the hitch ball.
- Never exceed the load capacity.
- Never use the power tongue jack to lift the trailer for service or tire change.
- Never move the trailer before the power tongue jack is fully retracted.
- Never use the power tongue jack unless the footpad clevis pin and hairpin cotter pin are fully inserted through both sides of the jack’s inner tube.

## Operation

**NOTE:** The ON and OFF light switch (Fig. 2) controls the power tongue jack's light only. If left on for an extended period of time, the light will drain the trailer's battery.

**NOTE:** The power tongue jack is designed for vertical movement of the trailer only.

### Unhitching From Tow Vehicle

1. Chock the tires of the trailer.
2. Make sure the footpad of the power tongue jack is pinned securely in place with the clevis pin and hairpin cotter pin (Fig. 1A).
3. Make sure the ground surface under the power tongue jack is firm and level.
4. Push EXT (Fig. 2B) to extend the power tongue jack until the footpad touches the ground and the coupler clears the hitch ball.
5. Disconnect all electrical and mechanical connections between the trailer and tow vehicle.
6. Move the tow vehicle away from the trailer.
7. Push RET (Fig. 2A) as needed to return the front of the trailer to level.

### Hitching to Tow Vehicle

1. Chock the tires of the trailer.
2. Press EXT (Fig. 2B) if needed to allow the coupler to clear the hitch ball.
3. Push RET (Fig. 2C) to retract the power tongue jack until the coupler properly mounts the hitch ball and the leg of the power tongue jack is fully retracted.

**NOTE:** Make sure the leg of the power tongue jack (Fig. 1B) is fully retracted prior to moving the tow vehicle.

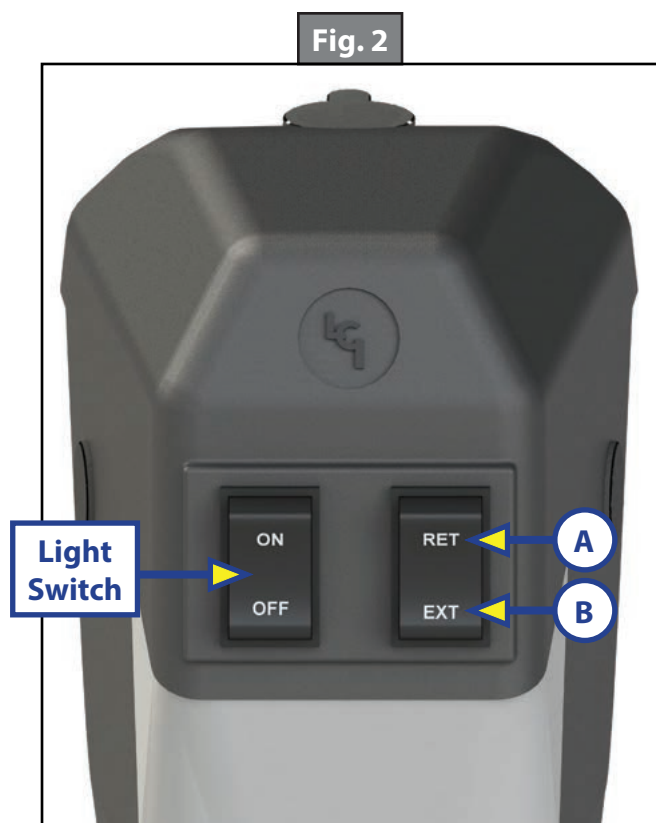
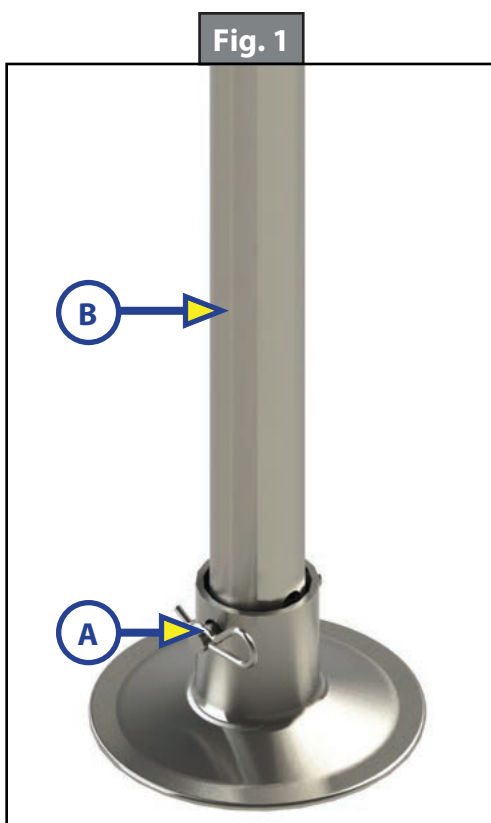

## Manual Operation

**NOTE:** In the event of loss of power, the power tongue jack can be operated manually.

1. Manually Unhitching from Tow Vehicle
  - A. Chock the tires of the trailer.
  - B. Be sure the footpad of the power tongue jack is pinned securely in place with the clevis pin and hairpin cotter pin (Fig. 3A).
  - C. Make sure the ground surface under the power tongue jack is firm and level.
  - D. Open the rubber plug (Fig. 4A) on top of the power tongue jack's gearbox to expose the manual drive shaft.
  - E. Insert the manual crank handle (Fig. 5).
  - F. Turn the handle clockwise until the trailer is supported and the coupler clears the hitch ball.
  - G. Move the tow vehicle away from the trailer.
  - H. Lower the trailer until it is level by turning the crank handle counterclockwise.
  - I. Remove the crank handle (Fig. 5).
  - J. Replace the rubber plug (Fig. 4A).
2. Manually Reconnecting to Tow Vehicle
  - A. Chock the tires of the trailer.
  - B. Be sure the footpad of the power tongue jack is pinned securely in place with the clevis pin and hairpin cotter pin (Fig. 3A).
  - C. Open the rubber plug (Fig. 4A) on top of the power tongue jack's gearbox to expose the manual drive shaft.
  - D. Insert the manual crank handle (Fig. 5).
  - E. Turn the crank handle counterclockwise until the coupler properly mounts the hitch ball and the leg of the power tongue jack is fully retracted.
  - F. Remove the crank handle (Fig. 5).
  - G. Replace the rubber plug (Fig. 4A).

**NOTE:** Be sure the leg (Fig. 3B) of the power tongue jack is fully retracted prior to moving the tow vehicle.

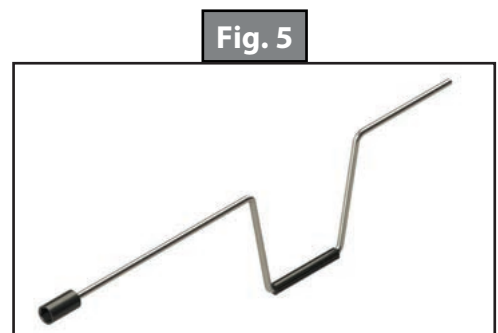
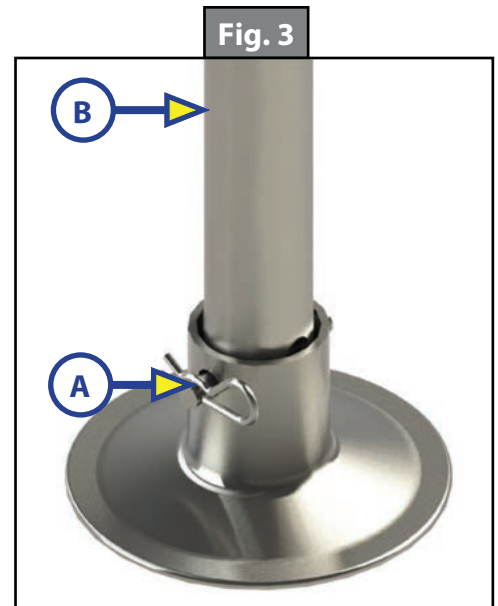

## Troubleshooting

### Fuse

1. The power tongue jack has a motor, clutch and a 30A fuse. The 30 Amp fuse will be located in-line and will need to be replaced with a 30A ATO-type fuse if it blows.
2. The battery must be fully charged prior to operating the power tongue jack. Low voltage from the battery will cause the fuse to blow prematurely.
3. The ON and OFF switch (Fig. 2) controls the power tongue jack's light only. If left on for an extended period of time, the light will drain the trailer's battery.

### Clutch

The clutch will slip under two conditions:

1. The power tongue jack has reached its extend or retract limit.
2. The tongue weight of the trailer has exceeded the capacity limits of the power tongue jack.
  - A. Items stored in the trailer can vastly influence the weight distribution of the power tongue jack. Reorganize stored items if the power tongue jack motor clutch continues to slip.
  - B. Release the switch immediately when the clutch noise occurs. The clutch is the overload protection for the motor. The clutch should not slip during normal operation. This will cause excessive wear on the clutch and the motor.

## Additional Information Sources

Additional information about this product can be obtained from [lci1.com/support](http://lci1.com/support) or by downloading the free myLCI app. The app is available on iTunes® for iPhone® and iPad® and also on Google Play™ for Android™ users.

iTunes®, iPhone®, and iPad® are registered trademarks of Apple Inc.

Google Play™ and Android™ are trademarks of Google Inc.

# POWER TONGUE JACK ASSEMBLY

## LEVELING AND STABILIZATION

Power Tongue Jack Kit - Part #285318

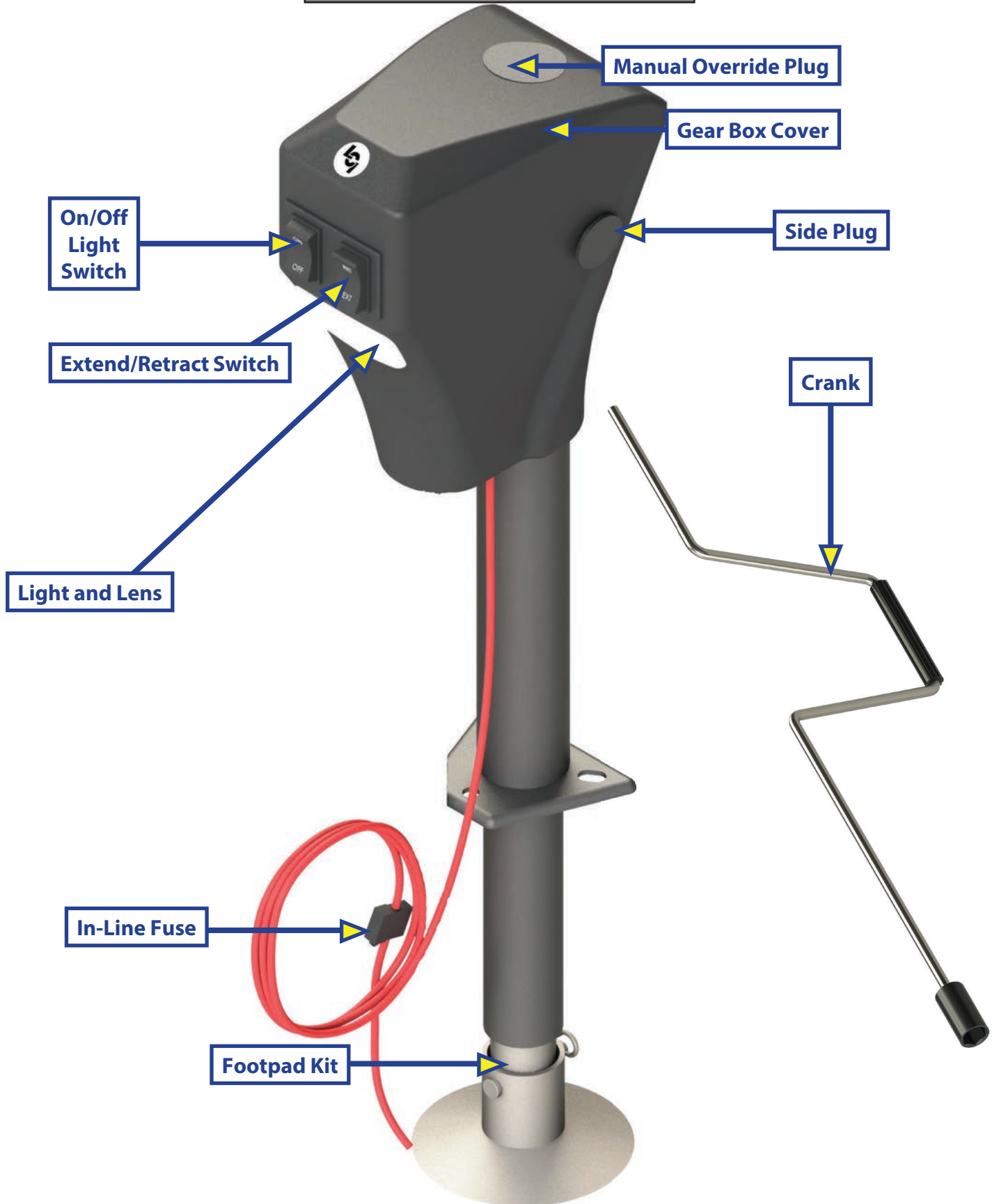



## LEVELING AND STABILIZATION

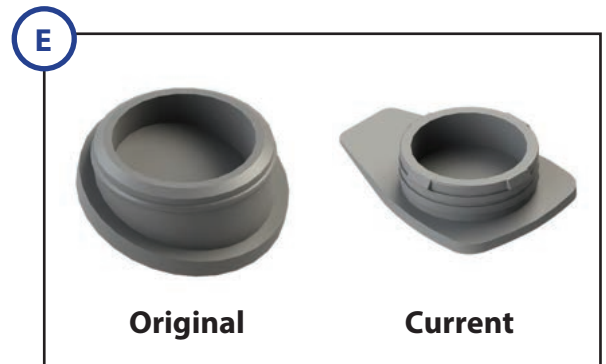
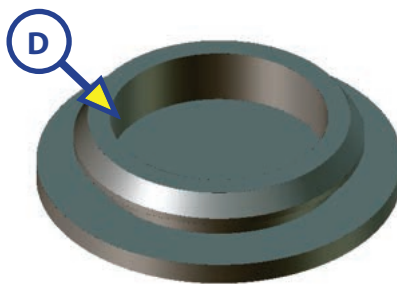

Callout	Part #	Description
A	<a href="#">285318</a>	Power Tongue Jack
B	<a href="#">285160</a>	Cover
C	<a href="#">165253</a>	Footpad Kit
D	<a href="#">225875</a>	Side Plug
E	225876	Manual Override Plug (Original)
	321807	Manual Override Plug (Current)
F	<a href="#">225885</a>	Lens



## LEVELING AND STABILIZATION

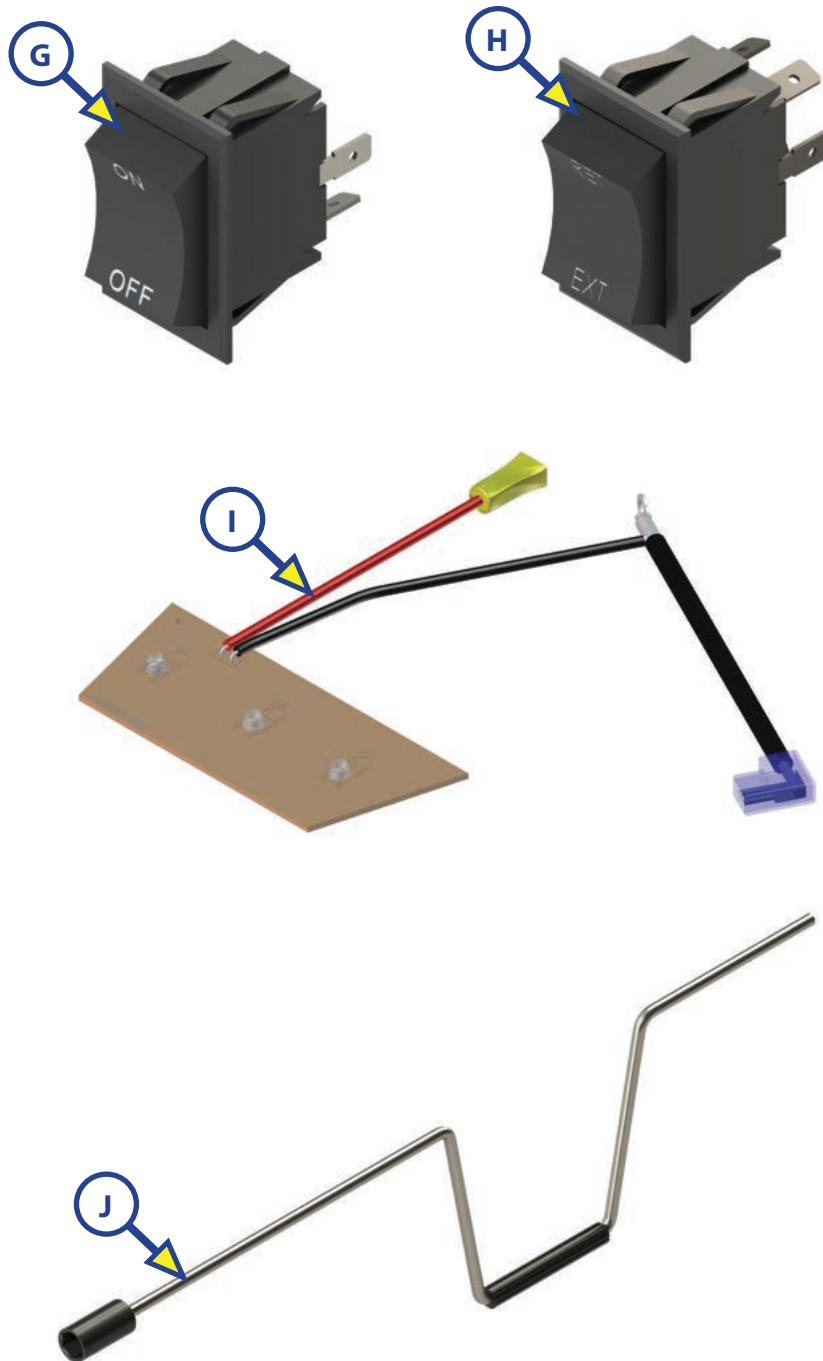

Callout	Part #	Description
G	<a href="#">226018</a>	On/Off Switch
H	<a href="#">226023</a>	Extend/Retract Switch
I	<a href="#">226027</a>	Light
J	<a href="#">116112</a>	Crank Handle



# L I P P E R T C O M P O N E N T S<sup>®</sup>

The contents of this manual are proprietary and copyright protected by Lippert Components, Inc. ("LCI"). LCI prohibits the copying or dissemination of portions of this manual unless prior written consent from an authorized LCI representative has been provided. Any unauthorized use shall void any applicable warranty. The information contained in this manual is subject to change without notice and at the sole discretion of LCI.

Revised editions are available for free download from [lci1.com](http://lci1.com).

Please recycle all obsolete materials.

For all concerns or questions, please contact  
Lippert Components, Inc.

Ph: (574) 537-8900 | Web: [lci1.com](http://lci1.com) | Email: [customerservice@lci1.com](mailto:customerservice@lci1.com)